

SmartBox - Laptop 20

Advanced security at an affordable price!

SmartBox features sleek, classic styling; advanced digital electronics; solid steel construction; anti-tamper labyrinths; and user-friendly audit software. Its simple operation makes it the most user-friendly digital code safe on the market.

Standard Features

- Solid steel bolt locking mechanism
- Large LED display and keypad
- ADA compliant audible keypad
- 4-digit guest code
- Battery backup
- Battery auto-check and low battery warning

Security Features

- Emergency opening with Override Unit
- Override Unit downloads last 300 operations
- Override Units are PIN protected, unique to each user and licensed hotel
- Anti-tamper construction enhances security and offers protection against manipulation

Optional Accessories/Features

- Pedestal

External dimensions

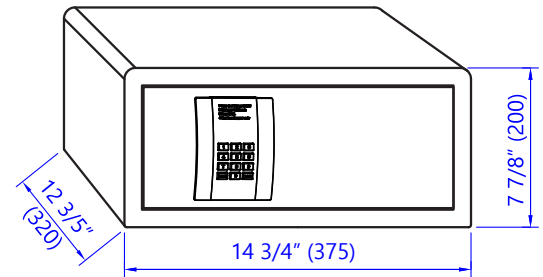

Front view

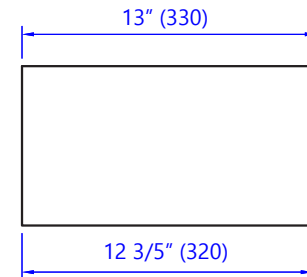

Side view

Installation

(The dimensions are from outside wall)

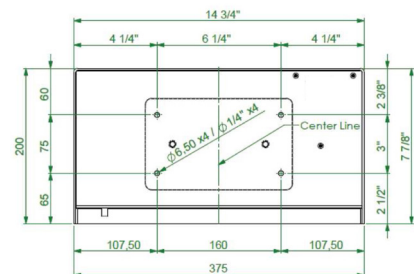

Installation from back

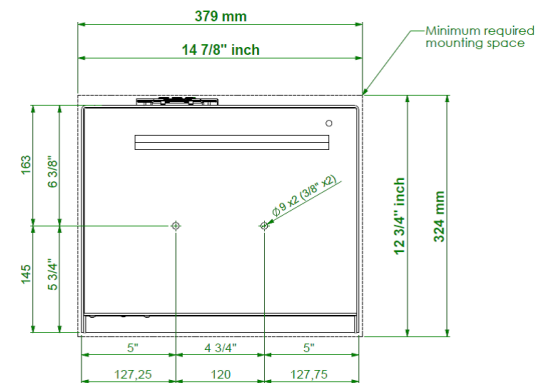

Installation from bottom

Technical Specifications



	SmartBox Laptop 20
Capacity (liters / cubic feet)	15L / 0.53Cu.Ft
Dimensions HxWxD (inches) Depth measured to faceplate (mm)	7.875 x 14.75 x 13 200 x 375 x 330
Door Hinge	Right Hinge Only
Interior Carpet Liner	Yes
Net Weight (lbs / kgs)	31 / 14.1
Gauge of Steel (Door / Body)	12 gauge / 9 gauge
Internal LED Light	No
Battery	5 AA alkaline batteries
Certification	ISO9001-2000 / CE / ROHS



www.MinibarSystems.com

DOC0278_SmartBox_Laptop_20

MINIBAR SYSTEMS
smart bars • smart people • smart solutions

Minibar North America
7340 Westmore Road
Rockville, MD 20850
tel 301 354 5055
fax 301 309 1115
info@MinibarNA.com